

Development and Prospect of Implantable Intra-Body Communication Technology

Shuang Zhang

1. College of computer science, Neijiang Normal University, Neijiang, 641000, China
2. The engineering & technical college of Chengdu University of Technology, Leshan, 614000, China
3. Biomedicine Department of Electrical and Electronics Engineering, Faculty of Science and Technology, University of Macau, Macau SAR 999078, China;
Email: zhangshuanghua@126.com

Yuping Qin^{2a}, Jiangming Kuang^{2b}, Peng Un Mak^{3c}, Sio Hang Pun^{3d}, Mang I Vai^{3e}, Yihe Liu^{1f*}

1. College of computer science, Neijiang Normal University, Neijiang, 641000, China
2. The engineering & technical college of chengdu university of technology, Leshan, 614000, China
3. Biomedicine Department of Electrical and Electronics Engineering, Faculty of Science and Technology, University of Macau, Macau SAR 999078, China;
Email: ^aqingyuping520025@126.com; ^b291806757@qq.com; ^cfstpum@eee.umac.mo; ^dlodge@mail.eee.umac.mo; ^ebme@eee.umac.mo; ^f (Corresponding author): liu_yihe@163.com

Abstract—The intra-body communication is an emerging wireless communication technology. It gives rise to slight wound without any infection, makes relevant devices positioned more easily and plays an important role in real-time monitoring of human body. According to coupling modes of electrodes, the intra-body communication is classified into two types, the capacitive and the galvanic coupling intra-body communication. By analyzing relevant achievements available, it is concluded that the capacitive coupling communication is inappropriate for the medical implant intra-body communication because this communication mode requires the common grounding, while the galvanic coupling communication can exactly make up for the disadvantage of the former. In existing research overview, prototypes and experiments concerning the two coupling communication modes are thoroughly discussed, and research status of “surface-to-surface”, “surface-to-implant”, “implant-to-surface” and “implant-to-implant” communication methods is emphasized as per installation positions of electrodes. Furthermore, opportunities and challenges of the communication technology are presented as well as its prospect. Although the galvanic coupling intra-body communication is confronted with many problems, it will be certain to be applied to the future implantable medical communication along with development of various related technologies and increasing demand for intelligent medical devices.

Index Terms—Intra-Body Communication, Capacitive Coupling, Galvanic Coupling, Implantable, Sensor

I. INTRODUCTION

As an important branch of the wireless sensor technology and an important public application network, the BAN (body area network) technology is significant and in great demand in many fields such as the remote medical treatment, the special population' nursing and health care for the community, which becomes the focus

in relevant study and application gradually. With the ongoing increase of the aging population all over the world, the medical resource (budgetary outlays, doctors, nurses, sickbeds etc.) is relatively insufficient, so this makes the development of the medical and health care system become the global demand [1]. However, China has a 1.3 billion population, so it is more urgent for China to develop the BAN technology so as to solve the problem of “hard and expensive to see a doctor” in most communities (especially remote mountainous regions) [2]. In addition, most traditional medical treatment methods are used only at the onset of illnesses, and fail to prevent sickness and implement real-time treatment. But new medical technologies represented by BAN can be used to provide early warning for an oncoming illness or give timely warning at the onset of the illness through classified-learning of the existing physiological data and analysis of real-time signals or data, and to save important physiological information at an attack of a disease for subsequent diagnosis and treatment.

The research work presented in this paper is supported by the Key Fund Project of Sichuan Provincial Department of Education under Grant 12ZB192, Grant 13ZA0003; the Science and Technology Development Fund of Macau (FDCT) under Grant 014/2007/A1, Grant 063/2009/A, and Grant 024/2009/A1; the Research Committee of the University of Macau, under Grant RG072/09-10S/MPU/FST; The Key Fund Project of Leshan Science and Technology Bureau under Grant 13GZD040. The Key Fund Project of Sichuan province academic and technical leader training funded projects under Grant 12XSJS002

*Corresponding author: Yi He Liu, E-mail: liu_yihe@163.com

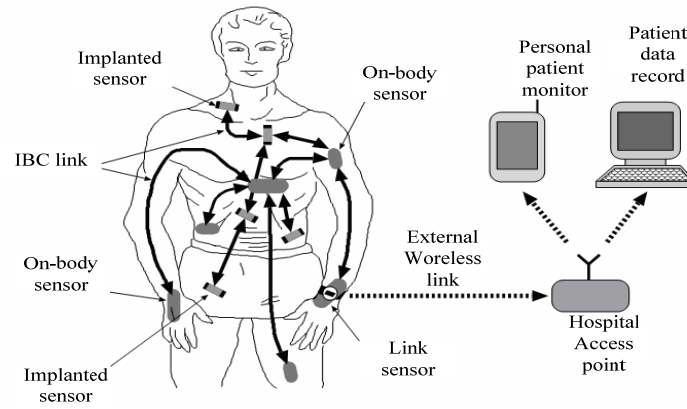

Figure 1. Wearable Medical Nursing System

BAN is established with some sensors mounted on human body surface or embedded in human body to achieve inter-communication through certain types of connection, and the system is generally called the medical nursing system [3], which is new and movable with the real-time monitoring function. The system has more than one basic module used for detection and processing of physiological signals, signal feature extraction and data transmission. Besides non-invasive and continuous monitoring, diagnosis and treatment of human body, the system can also be used for real-time display of users' health status and physiological information. Because the wearable medical nursing system can be seamlessly connected with WAN (wide area network), it is more helpful to implement regular monitoring and remote consultation for the people under care. Actually, the system (Figure 1) is a real-time monitoring network [4], in which the effective connection is built between various sensors and a base station (mobile phone, PDA and so on) mounted on the surface of human body. In general, these sensors can be connected with the base station through the following connection types: wired connection, wireless connection and intra-body communication.

The intra-body communication is an emerging wireless communication technology [5], in which signals are transmitted by virtue of good conductivity of human body. Therefore, the common short-distance wireless communication technology, in which air is used as the information transmission medium in the intra-body communication, plays an important role in the wearable medical nursing system due to low power consumption, strong anti-jamming ability against external

electromagnetic noise and less radiation energy [3] as well as no complicated wiring for signal transmission.

This paper starts with different coupling modes in the intra-body communication. Then we make a summary of existing achievements in the capacitive coupling and the galvanic coupling intra-body communication from researchers (or research organization), coupling modes, carrier frequencies, communication speeds, modeling methods, application fields and other aspects. Moreover, we present opportunities and challenges of the galvanic coupling intra-body communication so as to give comments and suggestions for further research.

II. RESEARCH PROGRESS OF INTRA-BODY COMMUNICATION

A. Capacitive Coupling Intra-body Communication

The intra-body communication was firstly proposed by the graduate student of MIT, Zimmerman and other researchers in 1995 [5], they used the transmitting electrode to input a 330 KHz weak signal (30V, 50PA) into human body. The signal was transmitted through human body and was received by the detecting electrode at a transmission rate of 2.4kbit/s, with power consumption of 1.5mW. In the system they designed, a transmitting electrode and a receiving one were mounted near human body to carry out the contactless coupling near human body by means of the capacitive coupling. However, another pair of electrodes (a transmitting electrode and a receiving one) was utilized to implement the ground coupling (Figure 2), which was called the capacitive coupling intra-body communication.

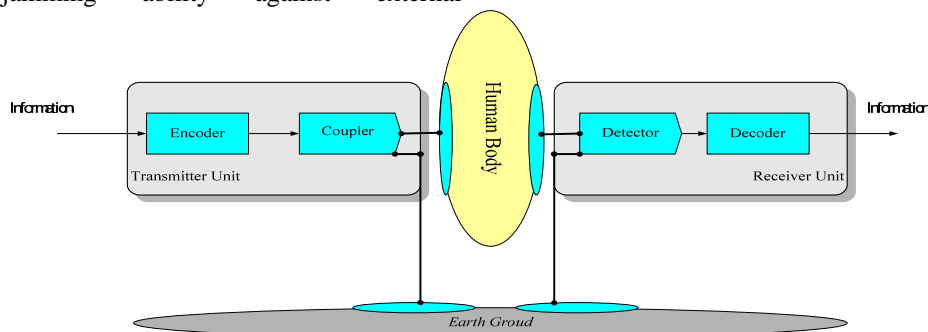

Figure 2. Zimmerman Intra-body Communication Model

The overall system was composed of the transmitting terminal, human body and the receiving terminal, and the signal electrode and the ground coupling electrode were placed at the two terminals respectively. The signal electrode was used for transmission and detection of signals; the electrode may contact human body, and it may also be placed near human skin. The grounding electrode was used to generate the signal circuit to the ground.

Since Zimmerman proposed the intra-body communication model, the capacitive coupling intra-body communication technology has been developed further. M.Gray [6] designed a device, of which the maximum theoretical bandwidth was raised to 2000kbps at the modulation frequency of 100 kHz. He showed that noise sources in the IBC device were mainly from the amplifier in the circuit and external electromagnetic interference. Next, E.R.Post [6] achieved the FSK (Frequency Shift Keying) half-duplex communication at a transmission rate of 9600 baud rate in his device, which meant that the intra-body communication had been developed for data and energy transmission through human body. Later on, K.Partridge [7] from University of Washington designed an improved device at a transmission rate of 38.4kbit/s. In the device, carrier frequencies of 180 kHz and 140 kHz were used in the FSK modulation mode, with the adjustable voltage (the maximum of 22V); on the basis of the above conditions, a large number of experiments were carried out in terms of signal intensity, transmission rate and other communication indexes. Those experiments showed that appearance of the grounding electrode of the transmitter (or the receiver) had no obvious effect on the signal, instead, the distance between signal electrodes produced a remarkable effect upon the signal, and the signal was attenuated more severely with the decrease of the ground contact area.

In 2004 NTT (the Nippon the Telegraph & Telephone) [8] from Japan published the RedTacton developed by themselves, which marked the beginning of practical application of the intra-body communication; in addition, they achieved the maximum half-duplex transmission rate of 10Mb/s. Later, an intra-body communication device named Wearable ID Key was also developed by Sony Corporation and Chiba University [9] of Japan. The transmission rate of the device reached 9600bps in the FSK modulation mode at the frequencies of 10MHz and

14MHz; above all, the first FDTD (Finite Difference Time Domain) simulation model relevant to the intra-body communication was proposed. It revealed the effect of the transmitting electrode's position on the received signal. JARuiz [8] from Waseda University used BAN as the background to analyze the mechanism and channel characteristics of the intra-body communication in the near zone field. On the basis of Zimmerman's achievement, the distributed RC model of the whole human body was proposed by Korea Advanced Manufacturing Research Institute [10] from the point of view of electric circuit. Compared with experiments, the model is exactly consistent with human experimentation within the range of 100KHZ to 150MHZ. They made a significant contribution to the study on the capacitive coupling intra-body communication, and made practical application of the intra-body communication come true from theoretical study.

It can be seen from the above conclusions that, both the prototype experiments and the finite element models focused on the surface of human body, in which the communication was limited to the "surface-to-surface" communication only, but it was not involved with the internal of tissues. Because the transmitter and the receiver must form a ground return circuit in the process of signal transmission, this way is unsuitable for the implantable intra-body communication.

B. Galvanic Coupling Intra-body Communication

Another kind of intra-body communication was proposed by Handa T etc. in 1997 [11], he placed an electrocardiogram monitoring device and a signal receiving device on human chest and human wrist, respectively. The signal transmitting electrode of the electrocardiogram (ECG) monitor sent a weak current signal to human body; the signal was transmitted to the receiving electrode of the receiving device on the wrist through human tissues so as to achieve signal transmission. They inputted about 20uA (effective value) alternating current in human body to realize ECG signal transmission in the body. In the whole process, the transmitting electrode and the receiving electrode must contact with human body which was regarded as a resistor to accomplish resistance coupling (Figure 3). This is termed the galvanic coupling intra-body communication.

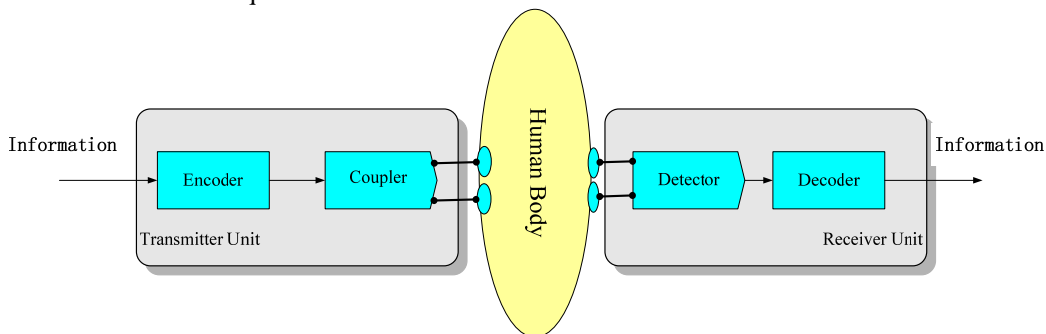

Figure 3. Galvanic Coupling Intra-body Communication Model

The system also has three components, the transmitter unit, human body and the receiver unit. Different from the capacitive coupling intra-body communication, electrodes of the transmitter and the receiver contact human body directly and the ground coupling is not required, which loosens restrictions on placement of devices. Its advantage lies in low power consumption, and only 8uW is required. Furthermore, the ground coupling is not required in the galvanic coupling intra-body communication, and the transmitter and the receiver directly contact with human tissues, so this kind of intra-body communication is applicable for the implantable device.

According to the installation depth of the transmitter and the receiver in human body, the galvanic coupling intra-body communication may be classified into the following types: “surface-to-surface” communication, “surface-to-implant” communication, “implant-to-surface” communication and “implant-to-implant” communication, which will be analyzed below, respectively.

1. Surface-to-surface Communication

During installing of communication devices, the signal transmitter and the signal receiver are placed on human skin, this may make devices mounted rapidly and easily and the surgery is not required to complete device installation and achieve communication, therefore it is noninvasive.

Modeling and verification

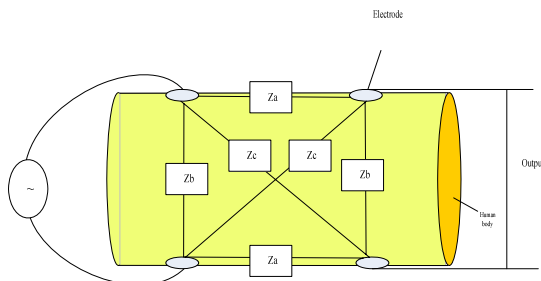

(a) Four-electrode model and

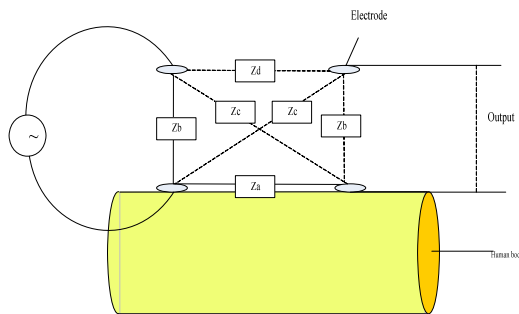

(b) Two-electrode model.

Figure 4. Intra-body Communication Mode Proposed by University of Tokyo

Since Handa.T [11] proposed the galvanic coupling intra-body communication, D.P.Lindsley etc. [12] from University of California took human body as the transmission medium of current signal, and used a novel

biomedical telemetry method to measure the tension of the fore cruciate ligament after surgery. After comparing effects of different carrier frequencies and currents on the signal attenuation, he finally proposed the best communication scheme, in which he used the 3mA current and the carrier wave of 37 kHz. On this basis, K.Hachisuka etc. from University of Tokyo presented the waveguide-mode intra-body communication, in which human body is regarded as a waveguide pipe to transmit the high-frequency electromagnetic waves generated at the transmitting terminal. Meanwhile, he built a simplified two-electrode intra-body communication model based on References [13], and presented the equivalent circuit models of the two-electrode model and the four-electrode model (Figure 4). On the basis of the model created by University of Tokyo, Y.Song [14] of Beijing Institute of Technology simplified the four-electrode circuit model (Figure 5) and provided the transfer function of the simplified model, finally derived the transfer function of the equivalent circuit through the input-output relationship. Note that a modified value K was firstly given in his paper to correct the difference between the individual simulated result and the measured result.

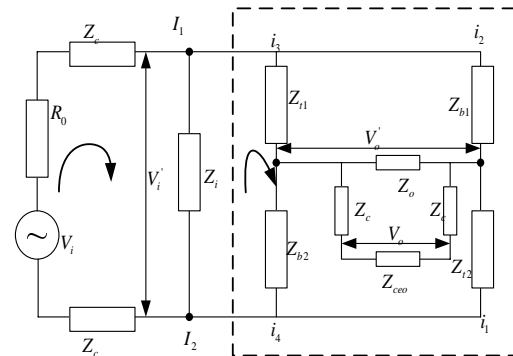

Figure 5. Four-electrode Circuit Model

M.Oberle [15] of Eidgenoessische Technische Hochschule Zuerich (ETH) designed a set of device capable of producing mA-level alternating current (through coupling) by means of dielectric properties of human tissue. Furthermore, he proposed a simpler engineering channel model as well. According to electromagnetic features of human tissue, M.S.Wegmuller etc. [16] subsequently built a preliminary finite element model and a layered tissue model of human forearm, and quantitatively compared effects of electrodes' size and position on signal attenuation. Note that M.S.Wegmuller used the carrier wave of 10 kHz to 1MHz as well as 1 mA orthogonal current in his experiment, achieving the maximum transmission rate of 4.8kbit/s. On the basis of the layered tissue model proposed by M.S.Wegmuller, Y.M.Gao of Fuzhou University and S.H.Pun [17] from University of Macau established the galvanic coupling intra-body communication channel model by means of the mathematical modeling for the first time.

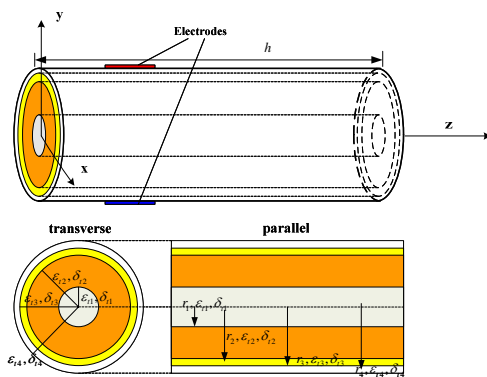

Figure 6. Equivalent Multi-layer Cylindrical Model of Human Arm

They took human arm as a standard cylinder (Figure 6) in which all layers of tissue were isotropic, and derived the voltage control equation of the galvanic coupling intra-body communication by means of the Maxwell

$$V(r, \phi, z) = \sum_{n=0}^{\infty} [A_n Z_n^{(1)}(kr) + B_n Z_n^{(2)}(kr)] [C_n \cos(n\phi) + D_n \sin(n\phi)] [E_k \cos(kz) + F_k \sin(kz)] \tag{3}$$

Where A_n , B_n , C_n , D_n , E_k and F_k are the undetermined constants; $Z_n^{(1)}(kr)$ and $Z_n^{(2)}(kr)$ may be Bessel functions $J_n(kr)$ and $Y_n(kr)$ respectively, or modified Bessel functions $I_n(kr)$ and $K_n(kr)$ respectively. Finally the solution of the model with N layers of concentric cylinders is derived on the basis of different boundary conditions. Establishment of the model provides theoretical support for the study of the intra-body communication for the first time. In combination with parameters involved with the analytical model of the intra-body communication electromagnetic field, 12 volunteers are chosen to carry out relevant experiments with 0.5mA current within the frequency range of 10 kHz to 1MHz. Experiments show that, the computed result of the analytical model of the intra-body communication electromagnetic field approximates to experimental results, so it can be used to explain all experimental phenomena reasonably. On the basis of achievements of Y.M.Gao and S.H.Pun, X.M.Chen [19] derived the transfer function of the voltage at human forearm, and then he inputted the 0.5mA electric signal with the carrier wave of 10Hz - 1MHz human skin to implement human experimentation. By comparing the experimental data and the calculating data, it can be concluded that the theory is reasonable.

Although the body-surface communication does not result in injuries to human body, signal distortion and great signal attenuation often arise because the sensors are relatively farther from the signal source. Meanwhile, the environment has a great impact on human body surface because movement is inevitable for a person, so relatively strong noise will be produced. For this reason, an appropriate detection method is required to make the sensors close to the signal source and less affected by the environment in order to reduce signal interference.

equation. According to the fact that the biological tissue meets the quasi-static conditions when the frequency is less than 1MHz, they derived the voltage equation as follows:

$$\nabla \cdot (\gamma \nabla V) = 0, \text{ where } \gamma = \sigma + i\omega\epsilon. \tag{1}$$

Because capacitance effect below 1MHz is negligible, so the complex permeability approximates to the conductivity and the control equation is simplified as follows:

$$\nabla \cdot (\sigma \nabla V) = 0 \tag{2}$$

Different intra-body communication models can be obtained from the different boundary conditions; the three-dimensional Laplace equation and separation of variables in the cylindrical-coordinate system are utilized to solve the control equation and the solution may be expressed as follows:

2. Implant-to-surface communication

In the implant-surface communication system, the current signal sent from the implantable device is used to implement current coupling with the surface-mounted device through human tissue, so as to achieve the implant-surface communication. In the system, relevant devices can be properly placed at desired positions and be repositioned. Because the signal-source detecting device is installed in human body, the detected source signal is less affected by the environment.

Design and verification of the system

Lindsey [20] implanted a sensor at the intersection of the fore cruciate ligament of a dead body's leg through the surgical operation, so as to measure ligamentous tension. The measured tension was converted into the current signal, which was transmitted to the detecting electrode mounted on human body surface via human tissues to achieve signal transmission. In the system, two electrodes with the diameter of 0.38mm were implanted in the dead body' leg at an interval of 2.5mm, and the electromyography (EMG) detecting electrode was placed on the surface of the leg. A 1 - 3mA sinusoidal signal with the carrier wave of 2-160KHZ was sent for test, producing the minimum signal attenuation of 37db. The signal attenuation here is easy to be affected, which is closely related to the current value, the distance between the built-in device and the surface-mounted electrodes and the interval between electrodes. Although the EMG detecting electrode may be repositioned at random, it is difficult to maintain high SNR in the communication due to the large signal attenuation (37-50dB).

A more efficient implant-to-surface communication system was proposed by SUN [21], in which the implanted transmitter was an integrated X-type antenna. They integrated two electrodes of the transmitter (or receiver) on a parabola-shaped surface, and made the X-type antenna on the insulating part generate current within a large range near the antenna by changing the

present current, so that the detecting electrode can detect more electric current. They conducted experiments with the saline water and the sedated pig respectively. In the experiments with the saline water, transmission of the X-type antenna signal needed only 1% of the power for the conventional electrode couple. Because the diameter of the X-type antenna was only 9mm, when the transmitter was implanted between the brain surface and the brain diaphragm, the system did not cause great injury to the inside of the brain. Therefore, it was feasible.

Although the signal source is near and random reposition of the detecting electrodes is available in this kind of communication, the signal must be transmitted through the skin and even more tissues before it is detected by the signal detection electrodes in the process of communication, because the emitting electrodes are installed in the tissues. This will lead to great signal attenuation and reduce the electric conductivity; meanwhile, because the emitting electrodes are installed in the tissues and the signal is relatively steady, it is adverse to transmission of the single-sensor multiple-frequency signal.

3. Surface-to-implant communication

The signal transmitter of the communication system is placed on the surface of the conductor, and the signal receiver is implanted inside a certain tissue. The signal transmitter sends a current signal, and the signal reaches the receiving electrode of the implantable device through the skin and other tissues so as to achieve communication, this communication mode is often used for electric energy transfer in the implantable device.

System design and rationality analysis

Z.D.Tang [22] proposed to transfer external electric energy to the implantable electronic components through the skin and tissues by virtue of biological tissue's volume conduction characteristics, so as to provide power supply for implantable devices. In order to analyze characteristics of the volume conduction energy delivery system effectively, the X-type equivalent circuit model

ler [23]. They simulated human muscular tissue and made two current coupling electrodes in the tissue send an alternating current signal into human body, which were detected by two detection electrodes implanted in the tissue. In order to avoid the common nerve frequency, they selected the current signal below 1 μ A within the frequency range of 100-500KHZ. To compare effects of different electrodes on signal attenuation, they also designed two kinds of receiving & transmitting electrodes, exposed copper cylindrical electrodes (10mm long, diameter of 4mm) and exposed copper coil (diameter of 4mm). Distance between these transmitting electrodes and receiving electrodes was 50mm. When the cylindrical electrode was chosen, the signal attenuation within 50mm was about 32dB, while the signal attenuation was approximately 47dB when the coil electrode was used. Therefore, it can be seen that different electrodes may produce different effects on signal attenuation and plenty of signal loss is caused by the four-electrode design, because most signals are directly transmitted back to the transmitter and the receiver receives few.

(with explicit physical significance) of the electrode - skin unit was built, and the computational formula concerning the X-type equivalent-circuit parameters and the open-circuit impedance of electrodes was derived. Meanwhile, through circuit analysis, the input loop impedance ratio (ILIR) was obtained as well as the impedance ratio and the voltage ratio ($V1/V2$) of the output loop. These parameters were used to determine the efficiency of volume conduction energy delivery. At the operating frequency of 5 kHz, he selected a piece of fresh pig skin to transmit the charging current of 2.8mA to the battery, and the transmission efficiency of the corresponding charging current reached 27%, together with energy transmission efficiency of 11%. It is thus proven that the external electric energy can be efficiently delivered to the implantable electronic devices in the living body through the skin by virtue of biological tissue's volume conduction characteristics.

Although random frequency modulation and electrode layout can be externally realized in this communication mode, there exists signal transmission through the skin, which results in great signal attenuation and poor efficiency.

4. Implant-to-implant communication

In the implant-to-implant communication system, the device implanted in a tissue sends a signal, which is transmitted to the receiving device in another tissue through in-between tissues to achieve signal transmission. The receiving device can send the signal out by means of the connecting line or radio frequency (RF). This type of communication has less power consumption than the implant-to-surface communication and the surface-to-implant communication, meanwhile, the external environment has less impact on sensors, with less signal attenuation and higher effective power.

Design and verification of the system

Design of the implant-to-implant communication system was proposed by M.S.Wegmul

Al-Ashmouny KM [24] designed a dual-electrode system which was used to experiment with a stupeficient mouse so that signal receiving ability of the receiver was improved. In the system, only two electrodes (included in the transmitter and the receiver respectively) contacted with its tissues. The two electrodes were composed of the platinum - iridium wire with a diameter of 50 μ m and an insulating CMOS chip, and their volume were around 1mm³. They were implanted in the brain of the mouse together with the AC signal electrode. Because the receiving circuit of the transmitter unit is insulating, the communication mode has a larger impedance ratio than the four-electrode circuit, and the signal transmission rate is higher accordingly. Note that the steady AC signal should be utilized to avoid injury to the tissue due to charge accumulation. The device was used to transmit the encoded neural signal, obtaining the signal attenuation of about 20dB. In the meantime, when the brain signal of the active stupeficient mouse was recorded, no obvious disorder occurred in the microelectrode recording. Although the system has a

high signal transmission rate, it is easy to be affected by the external current receiver. If a conductor with low impedance is used to form a closed circuit to the ground, e.g. human body contacts with the ground directly, signal loss arises easily.

III. OPPORTUNITIES AND CHALLENGES

A. Opportunities

A) In the intra-body communication, human body is considered a conductor capable of transmitting and receiving signals. Therefore, complicated wiring may be avoided. With the development of the micro electronic technology, the implantable medical devices become smaller and smaller, and these devices required in the intra-body communication cover less and less space, therefore, injuries to human body become slighter and slighter.

B) Strong anti-interference capacity. In the galvanic coupling intra-body communication, the current sent f signals are concentrated on tissues, so it is necessary to contact with the living body in order to gather signals, and signal transmission is very safe. Likewise, injuries to the living body are relatively slighter due to low frequency and small voltage and current; and electromagnetic burns will not happen in a short period.

B Challenges

1) Energy supply

The grand challenge in the medical implant communication is how to provide sufficient energy for devices to gather and transmit signals. Only two methods are adopted to solve the problem, one is to design the biological electric circuit with low power consumption; the other is external energy supply. With the development of the micro electronic technology, the circuit with low power consumption has been well applied to the implantable sensor technology [25]. The commonest energy supplying method for these devices is to use battery, for example, the cardiac pacemaker and deep brain stimulation devices are supplied with power through battery. However, it is difficult to achieve miniaturization in the battery design in order to meet requirements for energy supply. Meanwhile, because the service life of the battery is limited, it must be changed through surgery once the battery is used up, which will injure human tissues greatly. In order to reduce injury to human body, researchers also proposed a method called "external energy supply".

"External energy supply" is to transfer energy to the devices implanted in human body through wireless techniques. The radio-frequency (RF) technique is one important "external energy supply" method. At present, its development remains in the early phase without practical application. The wireless power transmission allows high-efficiency energy transfer through magnetic resonance coupling, but the larger coil is required to accomplish coupling [26], and more space is required for implantation, so it is very difficult to implant devices.

from the transmitting electrode flows through human body to achieve current coupling with the receiving electrode. Therefore, the anti-interference capacity of current coupling is stronger and more stable than capacitive coupling, which is beneficial to realization of the high-speed communication. Furthermore, the galvanic coupling electrode directly contacts with human body to form a closed circuit; however, in the capacitive coupling communication, the closed circuit is formed through the ground coupling. As a result, the capacitive coupling is not suited for communication between implantable medical devices at all.

C) Low carrier frequency, voltage and current, safe communication. Most carrier frequencies for the galvanic coupling intra-body communication are less than 1MHz; the current is several milliamper and the voltage is less than 5V [17][19]. Compared with the capacitive coupling intra-body communication, the frequency is relatively lower and most o

The ultrasonic energy transfer can also be used for implanted devices, but the transmission efficiency is very low (only 0.06% or so) [27], so it is hard to be developed for practical application. A survey on energy harvesting [28] and the optical energy [29] has been conducted, but at present the energy supplied via these means is very little, so it is difficult to meet steady operating requirements for implantable devices. The implantable radio frequency identification (RFID) method is also used to provide energy. In the overall system, the implantable device is just like an RFID device or an external source produced by conditioning signals. Coupling between the external signal and implantable devices is implemented through human brain tissues. The signal current is generated through the RF signal and the traditional RFID device [30] or by means of volume conduction. Because the battery is not required here, this method enables microminiaturization to the greatest extent. However, the inductance is used in the present research, so it is difficult to realize microminiaturization. The galvanic coupling is also used for power transmission, and Z.D.Tang has made quite a few achievements [31] in this aspect. Although major improvement has been made compared with previous similar researches, the efficiency is still low on the whole and it is difficult to meet requirements for the working environment of sensors.

2) Implantation of devices

The way that a device is implanted is closely related to its size. If the implanted device has a large volume, it is usually implanted by means of surgery [16]. If the device is small, it may be implanted through injection. The needle is firstly inserted to the subcutaneous tissue, and then the sensor is pressed into the subcutaneous tissue through the normal saline or air. This technique is often employed to identify dead animals by means of RF identification [31]. For the device implanted in the brain, when the hard needle is inserted in the cerebral cortex or the brain with meninx protection, large force is required to pierce the brain.

However, brain tissue has a larger volume than encapsulated tissues, and the pressure applied out of the injector may injure brain tissues [16]. Vacuum tools are used to replace subcutaneous injection, which is similar to the vacuum sensor. After the implantable device is placed in a vacuum tube, once the vacuum tube is inserted until the desired depth, the device is released and the vacuum tube is withdrawn.

The other implantation method is to embed the implantable device by means of magnetic navigation. The magnetic conduit [32] in the brain and the nano-drug delivery technique [33] are firstly developed. In the magnetic navigation, a permanent magnet is embedded in the implantable device, which is made to enter human body through injection or swallowing and is positioned by means of external magnetic guidance. The equipment is capable of 3D fine positioning and reposition. Its shortcoming is to require the implantable device with strong magnetic sensitivity and permanent magnetism. Meanwhile, environmental magnetic force and nuclear magnetic resonance are likely to result in shifting of the device.

In recent years, the fusible thin film has been used to fix the electrode network on the surface of the brain [34], and it is also applied to the implantable miniature device. The fusible thin film will be gradually separated from the device and fiber as time goes by, and decomposed within several days or weeks. But its safety and stability is required to be investigated and tested.

3) Communication security

In the actual communication, a man equipped with the implantable device shall not be injured or injury to him shall be minimized. From overseas research conclusions concerning medical implant communication, we learn that, when an implantable device is fixed in human body for a short or long period, complicated reaction will occur on the surface of human body [35]. The reaction may have an effect on functions of the implantable device. In order to reduce damage to human tissues, health organizations are seeking various methods to achieve safe application of implantable devices, including selection of compatible materials and coating [36] as well as delivery of local medicine [37].

It is very important to reduce impacts of the intra-body communication upon human body, including local temperature rise caused by power loss as well as local stimulation. In order to avoid local temperature rise, we choose the intra-body communication. Compared with RF identification, the low-frequency carrier wave is often used in the galvanic coupling intra-body communication, and only the carrier wave less than 1MHz is chosen under ideal conditions [17][19]. Meanwhile, the carrier frequency should be higher than the frequency for physiotherapy in order to minimize stimulation to human tissues, or at least 100KHZ is chosen as the carrier frequency. Within the range of 100KHZ to 1MHZ, biological tissues have good electrical conductivity [38]. Even if these intermediate frequencies are used, it is necessary to notice specific absorption rate (SAR) of organic energy and select the electric current density

below the international standard [38], because the intra-body communication is an emerging communication technology, potential temperature rise of tissues and stimulation to tissues are yet indeterminate. Even if the communication mode has been accepted by the relevant international standard, they must be closely monitored in future experiments.

4) Physical model of channel

The circuit model is one of the commonest approaches to build the intra-body communication channel model. In the model, electrodes and human tissues are considered to be interconnected ideal circuit elements (resistors and capacitors) which are connected through the ideal wire. The modeling method is quite simple, but it can show effectively the electrical resistance properties of signals and tissues.

The finite element model is a method to solve approximate solutions in modeling the communication channel [40]. In the model, human body is considered to be composed of numerous small interconnected sub-domains called the finite element. Each element is supposed to have a simple and appropriate approximate solution, and then the general boundary condition (e.g. an equilibrium condition of a structure) of the domain is derived, so as to obtain the solution to the problem. The solution is not the exact solution but the approximate solution, because the practical problem is replaced by the simpler.

Whether the circuit model or the finite element model is used to simplify modeling, both of them cannot present characteristics of the intra-body communication channel well, failing to focus on the general applicability of distribution and transmission mode of the electric signals inputted in human body. Moreover, they cannot be used to interpret essentially internal mechanisms and external factors affecting the quality of the intra-body communication. For this reason, a more accurate modeling method is required to describe these mechanisms.

S.H.PUN, Y.M.GAO [17] [19]etc. abstracted human arm as a homogeneous isotropic multi-layer cylinder; moreover, they derived the control equation of the intra-body communication according to Maxwell's Equation, and established the electromagnetic model of the galvanic coupling intra-body communication of the surface communication in combination with relevant boundary conditions and linking conditions. The classical electromagnetic theory was used to analyze relevant parameters in the model, which demonstrated distribution and transmission of the electric signal when the weak AC was inputted. And then internal and external factors affecting channel characteristics were analyzed and causal relation between phenomena and mechanisms was interpreted. However, it was the surface communication channel model built under the ideal condition and in the quasi-static mode [19], leaving out anisotropic property of tissues [41]. In the actual human tissue, the parallel and the transverse characteristics of the tissue are not identical [41], even the parallel and the transverse electrical characteristics of some tissues are greatly

different ($2.04 < \frac{\delta_L}{\delta_T} < 15.3$) [41]. In most of existing

models, only a certain part of human body is considered. If the whole body is taken into account, how should the geometric model be connected? With the continuous increase of the frequency, the quasi-static condition will be completely true no longer. When the implantable device transmits signals from inside to outside, the existing channel model will not be able to interpret transmission characteristics of signals completely; even the position where the device is mounted will have a direct impact on transmission characteristics of signals. Under various complicated conditions, the intra-body communication channel model will be greatly changed. In order to show signals' transmission characteristics in human body better, these problems will be gradually considered in future channel models.

5) Communication speed

The galvanic coupling intra-body communication has stable and strong anti-interference performance and is suitable for the implantable communication; instead, its communication speed is very low because of restriction on the communication frequency. The existing research achievements show that, its maximum communication speed is only 9.6Kbps/s. Physiological signals of human body at the speed can be transmitted basically in a real-time way. However, it is very difficult if it is used to transmit consecutive big-data signals such as video and audio signals. The research of the galvanic coupling intra-body communication will focus on how to improve the communication speed within the limited bandwidth.

IV. PROSPECT OF IMPLANTABLE INTRA-BODY COMMUNICATION

Although the medical implant communication with human body as the transmission channel was proposed and passed relevant testing, each method applied to the communication has its advantages and shortcomings. Compared with the wired connection and the RF wireless transmission, the intra-body communication has an irreplaceable advantage. However, the intra-body communication is an emerging technology, and it will be confronted with challenges in all aspects, especially increase of the carrier frequency and safety problem of living body. These problems must be solved before practical application in the clinical medicine.

Recently, most users applying the intra-body communication technology are still researchers in medical laboratories. The technology is mainly used in experiments with small animals such as mice and pigs to carry out functional test and extraction and correction of parameters. With the improvement of science and technology, the micro electronic technique is continuously developed and applied to the physiological monitoring step by step. Firstly, various subminiature monitoring devices are fixed at different positions of the object subject to implantation. A special transmission frequency is provided for each implantable device, so the device can finish independent addressing through the

body area network. Because human body is conductive and all implantable devices in the system are not restricted by the connecting wire, it is unnecessary to worry about tissue infection and injury to tissues. Therefore, flexible positioning is allowed. In particular, if the technology is applied to electroencephalogram signal acquisition, researchers may optionally choose a position to acquire the desired signal. Since most of nerve diseases (e.g. epilepsy) have an effect on all encephalic regions of the brain and the signal is produced in a real-time way, it is quite important to monitor neural activity of the brain and response of internal encephalic region to the signal. However, it cannot be accomplished through our existing technologies.

According to existing research work, it can be seen that most achievements concerning the galvanic coupling intra-body communication are still experiments or experimental prototypes, and channel models still remain circuit models or the finite element models. These models cannot show the transmission mechanism of signals well; moreover, because tissues are different as the position changes, they cannot reflect dependency of tissue characteristics and signal transmission. For this reason, it is significant to establish a reasonable mathematical model of the implant intra-body communication channel. Not only can the model reflect channel characteristics, but also it can simulate effectively signal transmission in the channel.

V CONCLUSION

The intra-body communication is an emerging wireless communication technology, in which human tissues are regarded as the communication wire and human body as the communication channel, so as to achieve communication through coupling of electrodes. This type of communication plays a significant role in real-time medical monitoring of human body because of slight wound, no infection and easy positioning of devices.

The galvanic coupling intra-body communication plays an important role in the medical implant communication because of no ground coupling, less effects produced by the external environment and low carrier frequency. But this technology is not proven at present and cannot be applied to practical medical monitoring; especially the mathematical model of the medical implant communication has not been established, and characteristics of the intra-body communication channel cannot be shown, so the technology will be applied practically after a certain period of time.

In this paper, firstly, research status of the capacitive coupling intra-body communication is analyzed in chronological order. It is found from the above analysis that the communication mode cannot be applied to the medical implant intra-body communication. Fortunately, the galvanic coupling intra-body communication may make up for the defect. Next, research status of the "surface-to-surface" communication, the "surface-to-implant" communication, the "implant-to-surface"

communication and the “implant-to-implant” communication is analyzed as per positions where electrodes are mounted. Finally, opportunities and challenges of the technology are presented as well as its prospect. In addition, solutions to some problems mentioned in this paper will be shown in a separate paper.

ACKNOWLEDGEMENTS

The research work presented in this paper is supported by the Key Fund Project of Sichuan Provincial Department of Education under Grant 12ZB192, Grant 13ZA0003; the Science and Technology Development Fund of Macau (FDCT) under Grant 014/2007/A1, Grant 063/2009/A, and Grant 024/2009/A1; the Research Committee of the University of Macau, under Grant RG072/09-10S/MPU/FST; The Key Fund Project of Leshan Science and Technology Bureau under Grant 13GZD040; The Key Fund Project of Sichuan province academic and technical leader training funded projects under Grant 12XSJS002.

REFERENCES

- [1] Nat arajan A, Motani M, de Silva B, et al. “Investigating network architectures for body sensor networks”. Proc of the 1st ACM SIGMOBILE International Workshop on Systems and Networking Support for Healthcare and Assisted Living Environments (Health Net07) . New York: ACM, 2007: 19-24
- [2] Yun D, Kang J, Kim J E, et al. “A body sensor network platform with two level communications”. Proc of IEEE Int Symp on Consumer Electronics. Washington: IEEE,2007: 1-6
- [3] Q.K. DENG.”A Novel Model of the Medical Instrumentation—An Overview of Wearable Sensors and Systems”. Chinese Journal of Medical Instrumentation, 2006, 30 (5):327-329.
- [4] G.Z. Yang. *Body Sensor Networks*. Springer, 2006. 20-22.
- [5] Zimmerman TG. “Personal area networks (PAN): near-field intra-body communication”. Master thesis, Massachusetts Institute of Technology, MA, USA (1995).
- [6] M.Gray.”Physical Limits of Intra-body Signalling”. Master thesis, Massachusetts Institute of Technology, 1997.1-49.
- [7] K.Partridge,B.Dahlquist,A.Veiseh,et al.”Empirical Measurements of Intra-body Communication Performance under Varied Physical Configurations”. Proceedings of the 14th annual ACM symposium on User interface software and technology table of contents, 2001.183-190.
- [8] M. Shinagawa, M. Fukumoto, K. Ochiai, et al.”A Near-Field-Sensing Transceiver for Intra-body Communication Based on the Electro-Optic Effect “. IEEE Trans. On Instrumentation and Measurement, 2004, 53(6):1533-1538.
- [9] K. Fujii, M. Takahashi, K. Ito.”Electric Field Distributions of Wearable Devices Using the Human Body as a Transmission Channel”. IEEE Trans. on Antennas and Propagation, 2007, 55(7):2080-2087.
- [10] N. Cho, J. Yoo, S. J. Song, et al. “The Human Body Characteristics as a Signal Transmission Medium for Intra-body Communication”. IEEE Trans. on Microwave Theory and Techniques, 2007, 55(5):1080-1086.
- [11] Handa T, Shoji S, Ike S, Takeda S, Sekiguchi T. “A very low-power consumption wireless ECG monitoring system using body as a signal transmission medium”. Int. Solid St. Sensor Actuator Conf. 1003–1006 (1997).
- [12] D. P. Lindsey, E. L. McKee, M. L. Hull, et al. “A new technique for transmission of signals from implantable transducers”. IEEE Trans. on Biom. Eng. ,1998.45(5):614-619.
- [13] K. Hachisuka, Y. Terauchi, Y. Kishi, et al. “Simplified circuit modeling and fabrication of Intra-body communication devices”. Sensors and Actuators, 2006.322-330.
- [14] Y.Song, Q.Hao, K.Zhang, M.Wang, Y.F.Chu, B.Z.Kang. “The Simulation Method of the Galvanic Coupling Intra-body Communication with Different Signal Transmission Paths”. IEEE TRANSACTIONS ON INSTRUMENTATION AND MEASUREMENT, 2011.60(4):1257-1266.
- [15] M. Oberle. “Low power system-on-chip for biomedical application”, PhD Thesis Diss.ETH, 2002.
- [16] M. S. Wegmuller. “Intra-Body Communication (IBC) for Biomedical Sensor Networks”. [PhD Thesis]. Switzerland: ETH, 2007.
- [17] S. H. Pun;Y. M.Gao; P. U. Mak; M.I Vai ; M.Du. “Quasi-Static Modeling of Human Limb for Intra-Body Communication (IBC)s With Experiments“. IEEE Transactions on Information Technology in Biomedicine,2011,15(6),870-876
- [18] R. Plonsey and E. B. Heppner, “Considerations of quasi-stationarity in electrophysiological systems,” Bulletin of mathematical biophysics. 1967 29: 657–664..
- [19] X.M.Chen, P.U.Mak, S.H.Pun, Y.M.Gao, C.T.Lam , M.I.Vai,M.Du. “Study of Channel Characteristics for Galvanic-Type Intra-Body Communication Based on a Transfer Function from a Quasi-Static Field Model”. Sensors 2012, 12, 16433-16450;
- [20] Lindsey DP, McKee EL, Hull ML, Howell SM. “A new technique for transmission of signals from implantable transducers”. IEEE Trans. Biomed. Eng. 45(5), 614–619 (1998)
- [21] Sun M, Mickle M, Liang W, Liu Q, ScLabassi RJ. “Data communication between brain implants and computer”. IEEE Trans. Neural Syst. Rehabil. Eng. 11(2), 189–192 (2003).
- [22] Z.D.Tang. “study on energy delivery rationale and method for implantable devices through volume conduction”. [PhD Thesis]. China: Chongqing University, 2007.
- [23] Wegmueller MS, Huclova S, Froehlich J et al. “Galvanic coupling enabling wireless implant communications”. IEEE Trans. Instrum. Meas. 58(8), 2618–2625 (2009).
- [24] Al-Ashmouny KM, Boldt C, Ferguson JE, Erdman AG, Redish AD, Yoon E. “IBCOM (intra-brain communication) microsystem: wireless transmission of neural signals within the brain”. In: Proceedings of the Annual International Conference of the IEEE Engineering in Medicine and Biology Society, 2054–2057 (2009).
- [25] Sarpeshkar R. “Ultra Low Power Bioelectronics: Fundamentals, Biomedical Applications, and Bio-Inspired Systems”. Cambridge University Press, Cambridge, UK (2010).
- [26] Kurs A, Karalis A, Moffatt R, Joannopoulos JD, Fisher P, Soljacic M. “Wireless power transfer via strongly coupled magnetic resonances”. Science 317(5834), 83–86 (2007).
- [27] Lee KL, Lau CP, Tse HF et al. “First human demonstration of cardiac stimulation with transcutaneous ultrasound energy delivery: implications for wireless

- pacings with implantable devices*". J. Am. Coll. Cardiol. 50(9), 877–883 (2007).
- [28] Justin GA, Zhang Y, Sun M, Sclabassi R. Biofuel cells: "a possible power source for implantable electronic devices". In: Proceedings of the 26th Annual International Conference of the IEEE Engineering in Medicine and Biology Society, vol. 2, 4096–4099 (2004).
- [29] Murakawa K, Kobayashi M, Nakamura O, Kawata S. A "wireless near-infrared energy system for medical implants". IEEE Eng. Med. Biol. 18(6), 70–72 (1999).
- [30] Riistama J, Aittokallio E, Verho J, Lekkala J. "Totally passive wireless biopotential measurement sensor by utilizing inductively coupled resonance circuits". Sens. Actuators A Phys. 157, 313–321 (2009).
- [31] Troyk PR. "Injectable electronic identification, monitoring, and stimulation systems". Annu. Rev. Biomed. Eng. 1, 177–209 (1999).
- [32] Grady MS, Howard MA, Dacey RG et al. "Experimental study of the magnetic stereotaxis system for catheter manipulation within the brain". J. Neurosurg. 93(2), 282–288 (2000).
- [33] Neuberger T, Schöpf B, Hofmann H, Hofmann M, Von Rechenberg B. "Superparamagnetic nanoparticles for biomedical applications: Possibilities and limitations of a new drug delivery system". J. Magn. Magn. Mater. 293, 483–496 (2005).
- [34] Kim DH, Viventi J, Amsden JJ et al. "Dissolvable films of silk fibroin for ultrathin conformal bio-integrated electronics". Nat. Mater. 9(6), 511–517 (2010).
- [35] Turner JN, Shain W, Szarowski DH et al. "Cerebral astrocyte response to micromachined silicon implants". Exp. Neurol. 156(1), 33–49 (1999).
- [36] Williams DF. "On the mechanisms of biocompatibility". Biomaterials 29(20), 2941–2953 (2008).
- [37] Onuki Y, Bhardwaj U, Papadimitrakopoulos F, Burgess DJ. "A review of the biocompatibility of implantable devices: current challenges to overcome foreign body response". J. Diabetes Sci. Technol. 2(6), 1003–1015 (2008).
- [38] Gabriel C, Gabriel S, Corthout E. "The dielectric properties of biological tissues: I. Literature survey". Phys. Med. Biol. 41(11), 2231–2249 (1996).
- [39] ICNIRP. "Guidelines for limiting exposure to time-varying electric, magnetic, and electromagnetic fields (up to 300 GHz)". Health Phys. 74(4), 494–522 (1998).
- [40] Yong Song, Kai Zhang, Qun Hao, Lanxin Hu, Jingwen Wang, Fuzhou Shang. "A Finite-Element Simulation of Galvanic Coupling Intra-Body Communication Based on the Whole Human Body". Sensors 2012, 12, 13567–13582.
- [41] F.L.H.Gielen, W. Wallinga-de Jonge, K.L. Boon. "electrical conductivity of skeletal muscle tissue: experimental results from different muscles in vivo". Medical & Biological Engineering & Computing. 1984.22:569-577.
- [42] Xiaolin Yi, Yishuang Ning. The Development of a Mobile Terminal Middleware Platform Based on HTML5. Journal of Software, 2013, 8(5): 1186-1193.
- [43] Xiangguo Cheng, Shaojie Zhou, Jia Yu, Xin Li, Huiran Ma. A Practical ID-Based Group Signature Scheme. Journal of Computers, 2012, 7(11): 2650-2654.
- [44] Xiao Chen, Chenliang Wu. Ultrasonic Measurement System with Infrared Communication Technology. Journal of Computers, 2011, 6(11): 2468-2475.
- [45] Kazuyuki Hanahara, Yukio Tada. Human-Robot Communication with Hand-Clapping Language (Consideration from Communication Impedance Matching Viewpoint). Journal of Computers, 2008, 3(9): 58-66.

Shuang Zhang received the Master degree in control Engineering from the Graduate University of Chinese academy of sciences, Beijing, China in 2011. Since 2011, he has performed research in the areas of Digital Image Processing, Digital signal processing, Intra-body communication. He is now an lecturer, department of electronic information and computer technologies, The Engineering & Technical college of Chengdu University of Technology. At the same time, He is now a Ph.D. student in the Department of Electrical and Electronics Engineering, Faculty of Science and Technology, University of Macau.

Yuping Qin received the Master degree in control Engineering from the Sichuan Normal University, Chengdu, China in 2011. Since 2011, he has performed research in the areas of Partial differential equation, Intra-body communication. He is now an lecturer, The Engineering & Technical college of Chengdu University of Technology.

Jiangming Kuang is now a lecturer, The Engineering & Technical College of Chengdu University of Technology.

Peng Un Mak received the B.Sc. degree from National Taiwan University, Taipei, Taiwan, and the M.Sc. and Ph.D. degrees from Michigan State University, East Lansing, all in electrical engineering. Since 1997, he has been an Assistant Professor in the Department of Electrical and Electronics Engineering, University of Macau, Taipa, Macau, China. His current research interests include bioelectromagnetism, intrabody communication and bioelectric signals acquisition.

Sio Hang Pun received the Ph.D. degree in electrical and electronics engineering from the University of Macau, Taipa, Macau, China, in 2011. Since 2000, he has been involved in research in the areas of biomedical engineering.

Mang I Vai received the Ph.D. degree in electrical and electronics engineering from the University of Macau, Taipa, Macau, China, in 2002.

Since 1984, he has been involved in research in the areas of digital signal processing and embedded systems. He is currently an Associate Professor and the Head of the Department of Electrical and Electronics Engineering, Faculty of Science and Technology, University of Macau.

Yihe Liu received the Ph.D. degree in Sichuan University, Taipa, Macau, China, in 2005. Since 2009, he has been involved in research in the areas of intra-body communication. He is currently an Professor, Neijiang Normal University.

TABLE 1
 TECHNICAL INDEXES OF GALVANIC COUPLING INTRA-BODY COMMUNICATION

Author	Year	Intensity of signal current	Specific application	Carrier frequency (Hz)	Modeling method	Human organ for modeling	Transmission rate	Communication mode
Handa [11]	1997	20uA	ECG	70K	Circuit	Arm	0.9K	<i>S-T-S</i>
Lindsey[20]	1998	3mA	EMG	37K	None	Leg	None	<i>I-T-S</i>
Oberle[15]	2002	4mA	NULL	60K	Circuit	NULL	4.8K	<i>NULL</i>
Hachisuka[13]	2006	1VPP	NULL	10.7M	Circuit	Arm	9.6K	<i>S-T-S</i>
Wegmuller[16]	2007	1mA	ECG	10K-1M	FEM	Arm	4.8K	<i>S-T-S, I-T-I</i>
Sio Hang Pun[17]	2011	1mA	ECG	1K-1M	Mathematical	Arm	None	<i>S-T-S</i>
Yong.Song[40]	2011	NULL	NULL	100k-5M	Circuit	Body	None	<i>S-T-S</i>
Yong.Song[40]	2012	NULL	NULL	100k-5M	FEM	Body	None	<i>S-T-S</i>

*S-T-S: Surface-to-surface; I-T-S: Implant-to-surface;I-T-I: Implant-to- Implant.