

Time-Varying Sliding Mode Adaptive Control for Rotary Drilling System

Lin Li

Key Laboratory of Drilling Rigs Controlling Technique, Xi'an Shiyou University, Xi'an, China
E-mail: kjclilin@xsyu.edu.cn

Qi-zhi Zhang and Nurzat Rasol

Key Laboratory of Drilling Rigs Controlling Technique, Xi'an Shiyou University, Xi'an, China
E-mail: zhangqzqz@gmail.com
E-mail: altiy@126.com

Abstract — This paper presents a time-varying sliding mode adaptive controller in order to handle the stick-slip oscillation of nonlinear rotary drilling system. The time-varying sliding mode controller with strong robust has two time-varying sliding surfaces, one of them induced time-varying integral sliding mode control can control the transient stage of the rotary drilling system and ensure the system remains the sliding condition whatever in usual or existing the parameter changes and disturbances to arrive at a controller capable of global stability. The herein developed controller is, a time-varying sliding mode adaptive controller has tracking performance and identification of drilling parameters. Lyapunov principles have been carried out to verify the stability and robustness of system. The simulation results show that the controller has faster dynamic responses and suppress stick-slip in oil well drill string, can achieve global stability of rotary drilling system.

Index term — time-varying sliding mode control, adaptive control, stick-slip, rotary drilling system, nonlinear system

I. INTRODUCTION

The complexity of drilling process, the uncertainties of rock formation and the operation characteristics of drilling rig result in unstable behavior and drill string component failures. Stick-slip phenomenon appearing at the bottom-hole assembly (BHA) is particularly harmful for the bit. When drillstring rotation begins, the drillpipe stores torsional energy until the applied torque exceeds the total static frictional torque on the BHA. The BHA then begins to rotate, and because the static friction is higher than the dynamic friction, the stored energy in the drillpipe is transferred to inertial energy in the BHA. It then can accelerate to a speed faster than steady-state rotational speed [1].

The great practical significance of oilwell drillstrings has interested some researchers. Some researchers hold the structure of bit is a major cause of the stick-slip oscillation, so they study to the mechanical structure [2]-[3] and the size [4]-[5] of the bit and analyze the stress of the bit in the drilling process[6]-[7]. At the same time, various solutions have been proposed in the

literature for controlling rotary system oscillation and to manipulate this problem of instability. For example, classical controller as PID [8], Backstepping control [9], H_∞ technique on the local linearized model [10], and finally, sliding-mode control has been effectively used in many practical control problems [11]-[12]. Now the proposed sliding control is a traditional sliding control way, although it has robustness, good dynamic and static characters, it can only achieve in the sliding surface, the transient stage of system has not any robustness during existing large errors or disturbances.

The paper presents time-varying sliding mode controller based on the nonlinear equation of the rotary drilling system for the stick-slip phenomena and the drawback of traditional sliding mode controller. It can achieve the global stability and robustness through the second order integral sliding surface during existing large error or disturbance and the numerical simulations have been carried out to verify the idea.

But we assume that the range of the parameters is known in the designed controller, however, it is difficult to accurately defined in the practical system, so the paper presents the way of combined the adaptive control with the time-varying sliding mode system and designs a two-layer sliding mode adaptive controller for rotary drilling system with adopting parameter adaptive method which can real time adjust controller parameters and provide the highlight advantages of the controller.

II. DRILLING WELL COMPONENTS

Deep wells for the exploration and production of oil and gas are drilled with a rotary drilling system. The basic components of a rotary drilling rig are the derrick and hoist, swivel, kelly, turntable, drill pipes, bit, and pump as shown in Fig.1. The torque driving the bit is generated at the surface by a motor with a mechanical transmission box or the top-drive. The medium to transport the energy from the surface to the bit is a drillstring, mainly consisting of drill pipes, drill collars and bit. The drillstring can be up to 8km long. The bottom end of the drillstring is the bottom-hole-assembly (BHA) consisting of drill collars and the bit, which

provides weight on the bit (WOB) required to generate accurate cutting force. During the process drilling, the drilling fluid (mud) is continuously circulated to the bottom of the hole and back to surface to remove cuttings from the bottom of the hole, to cool and lubricate the bit, and to control downhole pressures.

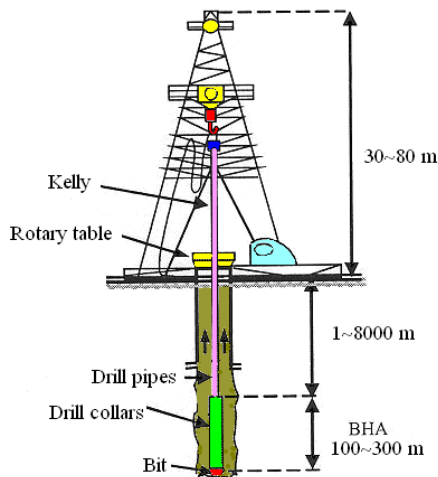

Figure 1. The rotary drilling rig

III. TORSIONAL MODEL OF A DRILLSTRING

The rotary drilling rig is an essential part of oil drilling which provides enough torque and rotary speed for the bit and the drilling devices. The basic components of a rotary drilling rig are the derrick and hoist, swivel, Kelly, turntable, drill pipes, bit, and pump.

Fig.2 depicts a simplified torsional model of the drill-string. The model essentially, consists of two damped inertias mechanically coupled by an elastic inertia less shaft (drillstring).

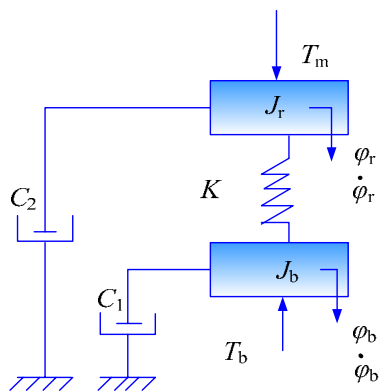

Figure 2. Drilling rotary system model

Some assumptions are made, such as: (a) the drillstring is homogenous along its entire length and simply considered as a single linear torsional spring with stiffness coefficient k. (b) the borehole and the drillstring are both vertical and straight, (c) no lateral hit motion is present, (d) the friction in the pipe connections and between the pipes and the borehole are neglected, (e) the drilling mud is simplified by a viscous-type friction element at the hit, (f) the drilling mud fluids orbital motion is considered to be laminar, i.e., without

turbulences [13]. Then, the equations of motion are given in [12] as

$$\begin{cases} J_b \ddot{\phi}_b + C_1 \dot{\phi}_b - k(\phi_r - \phi_b) = -T_{ob}(\dot{\phi}_b) \\ J_r \ddot{\phi}_r + C_2 \dot{\phi}_r + k(\phi_r - \phi_b) = T_m \\ T_m = C_2 \dot{\phi}_{ref} + u \end{cases} \quad (1)$$

where ϕ_b is the angular displacement of the bit, ϕ_r is the angular displacement of the rotary table or the top-drive, and $\dot{\phi}_{ref}$ is the desired velocity of the bit. J_b is the equivalent of moment of the inertia of the collars and the drillpipes, and J_r represents the inertia of the rotary table. C_1 is the equivalent viscous damping coefficient of BHA, and C_2 is the viscous damping coefficient of the rotary table. T_{ob} is a nonlinear function which will be referred to be the torque on-bit, and T_m is the torque delivered by the motor to the system.

In the oil drillstring, the stick-slip oscillations are driven by nonlinear friction T_{ob} at near-zero bit velocities. T_{ob} represents the combined effects of reactive torque on the bit and nonlinear frictional forces along the BHA. Fig.3 shows the excitation of torsional vibrations leading to the phenomena of stick-slip, by nonlinear friction torque between the drill bit and the rock formation. The friction torque T_{ob} as a function of the bit speed is given by the following nonlinear function:

$$T_{ob}(\dot{\phi}_b) = T_{obdyn} \frac{2}{\pi} (\alpha_1 \dot{\phi}_b e^{-\alpha_2 |\dot{\phi}_b|} + \arctan(\alpha_3 \dot{\phi}_b)) \quad (2)$$

Where $T_{obdyn}=0.5kNm$, $\alpha_1=9.5$, $\alpha_2=2.2$, and $\alpha_3=35$.

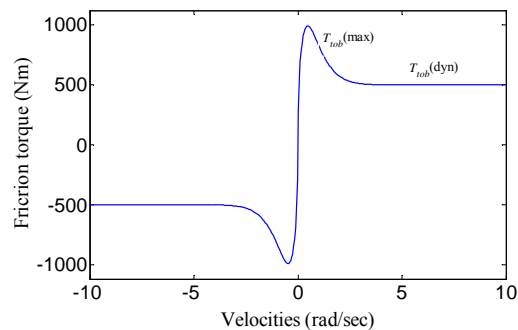

Figure 3. Torque as a function of the angular velocity at the bit

IV. CONTROLLER DESIGN

In this section, the main task is to design a controller to avoid stick-slip oscillations and optimize drilling process. The controller design procedure consists of two steps: first, in order to compensate the nonlinearity in the drilling caused by the oscillation of stick-slip and simplify the design of sliding surface, a description of the input-state linearization controller is derived; second, the two-layer time-varying sliding mode controller based on the linear equation of rotary drilling system is designed.

A. Input-State Linearization Controller

Consider the following nonlinear equation of the rotary drilling system given in (1)-(2):

$$\begin{cases} \dot{x}(t) = f(x(t)) + g(x)u(t) \\ y(t) = h(x(t)) \end{cases} \quad (3)$$

where $x(t) = [\dot{\phi}_b, \varphi_r - \varphi_b, \dot{\phi}_r]^T \in R^3$ is the state vector, $y(t) \in R$ is the measured output variable,

$$f(x) = \begin{bmatrix} -a_1\dot{\phi}_b + b_1(\varphi_r - \varphi_b) + c_1T_{lob}(\dot{\phi}_b) \\ \dot{\phi}_r - \dot{\phi}_b \\ -a_2\dot{\phi}_r - b_2(\varphi_r - \varphi_b) + c_2\dot{\phi}_{ref} \end{bmatrix}$$

$$g(x) = [0 \quad 0 \quad c_2]^T$$

$$h(x) = \dot{\phi}_b$$

where

$$a_1 = \frac{C_1}{J_1}, \quad b_1 = \frac{k}{J_1}, \quad c_1 = \frac{1}{J_1}, \quad a_2 = \frac{C_2}{J_2}, \quad b_2 = \frac{k}{J_2}, \quad c_2 = \frac{1}{J_2}$$

For reducing calculated amount the angular velocity of the bit is acquired by means of the input state. To find out the state transformation z , in case

$$\begin{cases} z_1 = \dot{\phi}_b \\ z_2 = \dot{z}_1 = -a_1\dot{\phi}_b + b_1(\varphi_r - \varphi_b) + c_1T_{lob}(\dot{\phi}_b) \\ z_3 = \dot{z}_2 = Hz_2 + b_1(\dot{\phi}_r - \dot{\phi}_b) \end{cases} \quad (4)$$

where for $\dot{\phi}_b$

$$H = -a_1 + c_1 \left[\frac{-2T_{lobdyn}}{\pi} (\alpha_1 e^{-\alpha_2 z_1} - \alpha_1 \alpha_2 z_1 e^{-\alpha_2 z_1} + \frac{\alpha_3}{1 + \alpha_3^2 z_1^2}) \right]^T$$

then the new state equations are in the canonical form

$$\begin{cases} \dot{z}_1 = z_2 \\ \dot{z}_2 = z_3 \\ \dot{z}_3 = Mz_2 + H^2 z_2 + H(z_3 - Hz_2) + b_1 Q + b_1 c_2 u \end{cases} \quad (5)$$

where

$$Q = -\frac{a_2}{b_1} (z_3 - Hz_2) + (a_1 - a_2)z_1 - (b_1 + b_2)\varphi + a_2\dot{\phi}_{ref} - c_1T_{lob}(z_1)$$

$$M = \frac{2c_1T_{lobdyn}}{\pi} \left[e^{-\alpha_2 z_1} (2\alpha_1\alpha_2 - \alpha_1\alpha_2^2 z_1) + \frac{2\alpha_3^2 z_1}{(1 + \alpha_3^2 z_1^2)^2} \right]$$

$$\varphi = \varphi_r - \varphi_b$$

Now, it is easy to observe that the input state vector

$$u_{lin} = \frac{1}{b_1 c_2} [v - (M + H^2)z_2 - H(z_3 - Hz_2) - b_1 Q] \quad (6)$$

B. Sliding Mode

The sliding mode control approach (see for example) [14]-[16] leads to a controller which can be stabilized over a wide range of operating conditions and is robust with respect to parameters variations. To track the bit angular velocity to the target, the error e is simply defined as

$$e = \dot{\phi}_b - \dot{\phi}_{ref} \quad (7)$$

where $\dot{\phi}_{ref}$ is the desired state of the system.

Therefore, the sliding surfaces can be chosen as

$$s = \lambda e \quad (8)$$

The input u is becoming

$$u = u_{lin} + u_{sm} \quad (9)$$

where u_{lin} is the input-state linearization controller defined in (9), u_{sm} is the sliding mode controller.

Usually, we can design sliding mode controller based on various reaching laws:

a) Constant rate reaching law

$$u_{sm} = -k \cdot \text{sgn}(s)$$

b) The index number reaching law

$$u_s = -k \cdot \text{sgn}(s) - \lambda_1 s$$

c) The exponent reaching law

$$u_s = -k|s|^\alpha \cdot \text{sgn}(s) - \lambda_1 \cdot s$$

C. Two-Layer Time-Varying Sliding Mode Controller

Two-layer time-varying sliding mode controller is presented for the drilling rotary system. Two-layer time-varying sliding mode controller has two time-varying sliding surfaces. One of them is stationary surface, as main surface; the other surface is a time-varying surface with integral sliding mode control. The initial state of drilling rotary system runs in the second order sliding surface that can control the reaching stage of main sliding surface, and the transient process of system can remain insensitive to parameter variations and other disturbances; at the same time, the reaching stage of the second order sliding surface can be cancelled because of the initiate state runs in there. The drilling rotary system is in the sliding condition all the time, therefore, the system with strong robustness can resist the stick-sliding oscillation of drill bit and ensure the global stability of system [17].

Appropriate time-varying sliding surfaces are most important to the design of sliding mode controller. The error e in the drilling rotary system is defined as:

$$e_1 = z_1 - \Omega_{ref} \quad (10)$$

According to (5), these errors can be considered:

$$e_2 = \dot{e}_1 = \dot{z}_1 = z_2 \quad (11)$$

$$e_3 = \ddot{e}_1 = \ddot{z}_1 = z_3$$

Then main sliding surface is defined as:

$$s_1(t) = \lambda e \quad (12)$$

where:

$$\lambda = [\lambda_1 \quad \lambda_2 \quad 1], \quad e = [e_1 \quad e_2 \quad e_3]^T$$

The second sliding surface induced integral sliding mode control in order to increase the accuracy and robustness [18]-[19], and it is defined as:

$$s_2(t) = s_1(t) + A \int s_1(\tau) d\tau + Q(t) \quad (13)$$

where

$$Q(t) = \begin{cases} Bt^2 + Ct + D & t \leq T \\ 0 & t > T \end{cases}$$

A, B, C, D are real constants, and $A > 0$.

When the initial state $t=0$, the $s_2(x, 0)=0$, hence

$$D = -\lambda_1(z_1 - \Omega_{ref}) - \lambda_2 z_2 - \lambda_3 z_3 \quad (14)$$

s_2 and its derivative is continuous, so

$$BT^2 + CT + D = 0$$

$$2BT + C = 0$$

Thus

$$B = \frac{D}{T^2}, \quad C = -\frac{2D}{T}$$

After this, we design the controller that not only ensures the sliding motion existence in the two-layer surface under the certain condition, but also the main sliding surface and the tracking error approximate to zero during the limited time.

The derivative of second order sliding surface is

$$\dot{s}_2(t) = \dot{s}_1(t) + As_1(t) + \frac{dQ}{dt} \tag{15}$$

$$= \lambda_1 z_2 + \lambda_2 z_3 + \dot{z}_3 + As_1(t) + \frac{dQ}{dt}$$

The state vector can be chosen according to the input state linearization control law [20]:

$$u = \frac{1}{b_1 c_2} [-Mz_2^2 - H^2 z_2 - H(z_3 - Hz_2) - b_1 Q - \lambda_1 z_2 - \lambda_2 z_3 - As_1(t) - \frac{dQ}{dt} - ks_2(t)] \tag{16}$$

V. THE STABILITY ANALYSIS OF DRILLING ROTARY SYSTEM

Oilwell drillstrings are mechanical system which undergo complex dynamical phenomena, often involving non-desired oscillations. These oscillations are a source of failures which reduce penetration rates and increase drilling operation costs. So it is an advisable decision to choose sliding mode controller for drilling rotary system. However, the traditional sliding mode controller for the transient state has not any robustness, when there are a large error or disturbance in the system, it can not remain its good performance, but the time-varying sliding mode control exception. There is the stability analysis of rotary drilling system as follows [21].

We can choose a positive Lyapunov function based on the error dynamics of the system as:

$$V_2 = \frac{1}{2} s_2^2(t) \tag{17}$$

and its time derivative is

$$\dot{V}_2 = s_2(t) \dot{s}_2(t) \tag{18}$$

Using (16), relation (15) takes following forms

$$\dot{s}_2(t) = -ks_2(t) \tag{19}$$

so

$$\dot{V}_2 = -ks_2^2(t) \leq 0 \tag{20}$$

Equation (20) indicates the sliding motion in the second order surface is existent and stable.

Also, we can choose another positive Lyapunov function based on the error dynamics of the system as:

$$V_1 = \frac{1}{2} s_1^2(t) \tag{21}$$

and the time derivative of (21) as

$$\dot{V}_1 = s_1(t) \dot{s}_1(t) \tag{22}$$

There are $s_2(t)=0$ in the second surface, then

$$s_1(t) + A \int s_1(\tau) d\tau + Q(t) = 0 \tag{23}$$

and the time derivative of (23) as

$$\dot{s}_1(t) = -As_1(t) - \begin{cases} 2Bt + C & t \leq T \\ 0 & t > T \end{cases} \tag{24}$$

so

$$\dot{V}_1 = -As_1^2(t) - s_1(t) \begin{cases} 2Bt + C & t \leq T \\ 0 & t > T \end{cases} \tag{25}$$

When $t > T$, then $\dot{V}_1 = -As_1^2(t) < 0$, there has the sliding motion that is stable according to Lyapunov principle.

For $t \leq T$

$$s_1(t) = \left[s_1(0) + \frac{C}{A} - \frac{2B}{A^2} \right] e^{(-At)} - \frac{2B}{A} t - \frac{C}{A} + \frac{2B}{A^2} \tag{26}$$

For $t > T$

$$s_1(t) = s_1(T) e^{[-A(t-T)]} \tag{27}$$

When $t \rightarrow \infty (t > T)$, $s_1 \rightarrow 0$ and consider with (26)-(27), the reaching stage of main sliding surface is the index number reaching, Previously, that has not any robustness in the traditional sliding mode control, but the reaching stage of $s_1(t)=0$ runs in the second order sliding surface of the time-varying sliding mode controller.

In the above, the drilling rotary system with the time-varying sliding mode controller has strong robustness to parameter changes and disturbances from beginning to end, as well as the system is in the sliding condition along the $s_2(t)=0$ until the s_1 approximate to zero, then it also is in sliding condition along the $s_1(t)=0$, so the whole system can achieve global stability and has strong robustness.

With $s_1(t) = 0$:

$$\sum_{i=1}^{n-1} k_i e^{(i-1)} + e^{(n-1)} = 0$$

where $k_1 + k_2 p + \dots + k_{n-1} p^{n-2} + p^{n-1}$ is Hurwitz polynomials, so the error $e = y - y_d$ will approximate to zero.

VI. TIME-VARYING SLIDING MODE ADAPTIVE CONTROL

There presents a sliding mode adaptive control for in the oil drilling system with large parameter changes and uncertainties which combines the adaptive control with sliding mode control. The sliding mode adaptive control can improve the control characteristic through adopting parameter adaptive control, on-line identification and tacking technology [17].

If M, H is uncertain, using estimated parameter, relation (16) takes the following form:

$$u = \frac{1}{b_1 c_2} [-\hat{M}z_2^2 - \hat{H}^2 z_2 - \hat{H}(z_3 - \hat{H}z_2) - b_1 Q - \lambda_1 z_2 - \lambda_2 z_3 - As_1(t) - \frac{dQ}{dt} - ks_2(t)] \tag{28}$$

where \hat{M}, \hat{H} are estimate of M, H .

We can choose a positive Lyapunov function V as:

$$V = \frac{1}{2} s_2^2 + \frac{1}{2} \rho_1 \tilde{M}^2 + \frac{1}{2} \rho_2 \tilde{H}^2 \quad (29)$$

where $\tilde{M} = M - \hat{M}$, $\tilde{H} = H - \hat{H}$.

The time derivative of (29) as:

$$\dot{V} = s_2 \dot{s}_2 + \rho_1 \tilde{M} \dot{\tilde{M}} + \rho_2 \tilde{H} \dot{\tilde{H}} \quad (30)$$

Using (28), relation (15) takes following forms:

$$\begin{aligned} \dot{s}_2(t) &= \dot{s}_1(t) + A s_1(t) + \frac{dQ}{dt} \\ &= \tilde{M} z_2^2 + \tilde{H}^2 z_3 + \tilde{H} (z_3 - \tilde{H} z_3) - k s_2(t) \end{aligned} \quad (31)$$

so

$$\dot{V} = \tilde{M} (s_2 z_2^2 - \rho_1 \dot{\tilde{M}}) + \tilde{H} (s_2 z_3 - \rho_2 \dot{\tilde{H}}) - k s_2^2 \quad (32)$$

We can choose following adaptive law according to the Lyapunov principle:

$$\begin{cases} \dot{\tilde{M}} = \frac{s_2 z_2^2}{\rho_1} \\ \dot{\tilde{H}} = \frac{s_2 z_3}{\rho_2} \end{cases} \quad (33)$$

Where $\dot{V} \leq 0$, semi-positive, and V is positive, so the system is stable according to Lyapunov method.

Considering the characteristic of the practical drilling, combined with the controller given (28) with adaptive law given (33) is an advisable way for the controlling rotary drilling system with many uncertainties. The rotary drilling system with time-varying sliding mode adaptive controller with strong robustness has the characteristic of identification and tracking, it can achieve global stability.

VII. SIMULATION RESULTS AND DISCUSSION

The time-varying sliding mode control has high quality for the system. This section presents the simulation results of the drilling rotary system with time-varying sliding mode controller.

The parameters, used for the simulation are taken from [12]. In addition these parameters are typical in oil well drilling operations.

Fig.4 shows the step response of the bit angular velocity without the controller. The effects of stick slip oscillations can be seen at the bit speed, which take more than 100 second to vanish.

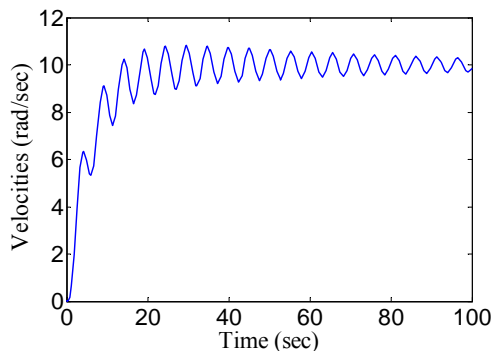

Figure 4. The step response of the bit angular velocity without the controller

Previously, we have designed the sliding mode PID controller with different reaching law and adaptive PID controller for rotary drilling system. Now we compare the characteristics of the time-varying sliding mode adaptive controller with previous work.

The Fig.5 shows the step response of bit angular velocity with sliding mode PID controller with different reaching law. From figure can be seen, the reaching law can affect the efficiency of suppressing stick-slip oscillation, where the exponent reaching law has good character for fast reaching spend and the constant rate reaching law although can suppress the stick-slip oscillation, the response curve of system is not smoothing [22].

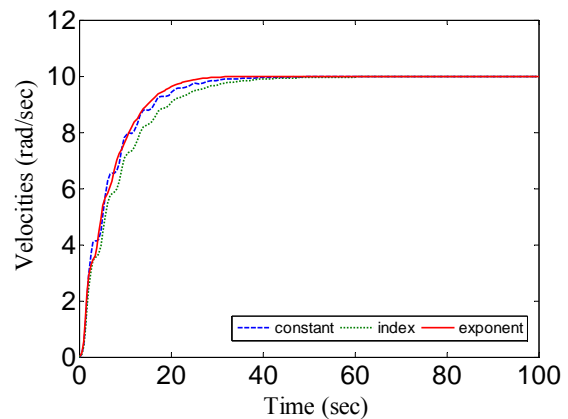

Figure 5. The step response of the bit angular velocity

The drawbacks of tradition sliding controller exist in the sliding controller with different reaching law. However, the time-varying sliding control can guarantee the stability of main sliding surface sliding motion and reaching stage.

Fig.6 shows the step response the drilling rotary system with adaptive PID controller. As seen the figure, although the adaptive PID controller has certain robustness, the drillingstring length changes bring some oscillation to system but the time-varying sliding controller exception, which is insensitive to drilling length changes

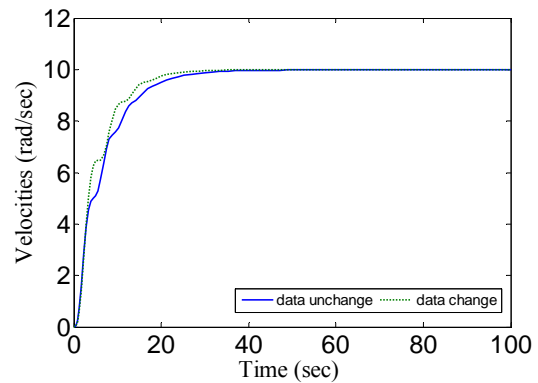

Figure 6. The step response of the bit angular velocity in adaptive PID controller

Fig.7 shows the step response of the bit angular velocity with the time-varying sliding mode controller. In

simulation sliding mode controller parameter $\lambda=[0.24 \ 0.6 \ 1]$, $A=0.29$, $k=0.0002$, $T=0.1s$.

As seen in the Fig.7, rise time $t_r \approx 12s$, settling time $t_s \approx 18s$, overshoot $\sigma\% = 0$, steady-state error $e_{ss} = 0$. Because of the second order sliding surface with integral sliding mode control, there are no more stick-slip oscillations as arising large errors or disturbances and increase the accuracy of system. All in all, the drilling rotary system with time-varying controller has faster response, dynamic and static characters.

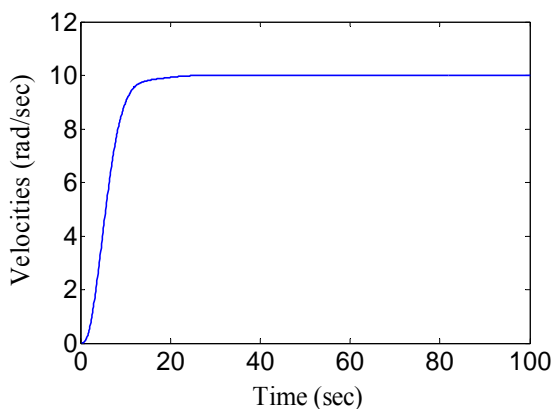

Figure 7. The step response of the bit angular velocity

If M, H is uncertain, we can get similar results through the tracking performance and identification ability of adaptive controller.

VIII. CONCLUSION

In this paper, we have proposed a time-varying sliding mode adaptive controller for handling the stick-slip oscillation and the drawbacks of traditional sliding mode control, from comparing the simulation results, we can get as follows:

- a) Time-varying sliding mode controller can ensure the stability and the robustness of transient stage.
- b) Time-varying sliding mode controller can suppress stick-slip in oil well drill string under existing large error or disturbance, achieve the global stability of rotary drilling system.
- c) Integral sliding mode control induced by time-varying sliding mode controller can increase the robustness and stable accuracy of the controller.
- d) The rotary drilling system has tracking performance and identification of drilling parameters from combined the sliding control with adaptive control.

ACKNOWLEDGMENT

This work was supported in part by a grant from the CNPC Science and Innovate Foundation Project: No.2009D-5006-03-07 and Key Project of Science and Technology Department of ShaanXi.

APPENDIX PARAMETER VALUES

PARAMETERS USED IN THE SIMULATION

Symbol	Description	Values
J_b	Drill bit inertia	374 kgm ²
J_r	Rotary table + motor inertia	2122 kgm ²
C_1	BHA damping	0.5 Nms/rad
C_2	Rotary table damping	425 Nms/rad
K	Drillstring stiffness	473 Nms/rad
Ω_{ref}	Drill bit reference velocity	10rad/s

REFERENCES

- [1] J.F.Brett. The Genesis of Torsional Drillstring Vibrations. SPE Drilling Engineering, vol. September, 1992: 168-174.
- [2] G. Mensa-Wilmot, M. Booth and A. Mottram. New PDC Bit Technology and Improved Operational Practices. Saves IM in Central North Sea Drilling Program. in the SPE/IADC Drilling Conference. New Orleans, 2000. SPE/IADC 59108.
- [3] Peng Ye. The Theory and Testing Study of Two-stage Bit[D]. China University of Petroleum Doctoral Dissertation, 2008.
- [4] Zhang Shaoping. Study and Application of Bit Selection for Zhongyuan Oil Field[D]. China University of Petroleum Doctoral Dissertation, 2007.
- [5] Pan Qifeng, Gao Deli, Sun Shuzhen, Sun Xiangcheng. A New Method for PDC Selection[J]. Acta Petrolei Sinica, 2005, 26(3): 123-126.
- [6] Guo Jian, Sun Wenlei. The Stress Analysis PDC Drill Bits in the Process of Drilling[J]. Machine Tool and Hydraulics, 2008, 36(12): 25-27.
- [7] J.D. Macpherson and PN. Jogi and J.E.E. kingman. Application and Analysis of Simultaneous near Bit and Surface Dynamics Measurements. SPE Drilling and Completion, 2001, 16(4): 230-238.
- [8] F.Abbassian and V.A.Dunayevsky. Application of Stability Approach to Torsional and Lateral Bit Dynamics. SPE Drilling and Completion, 1998, 13(2): 99-107.
- [9] F. Abdulgalil and H. Siguerdidjane. Backstepping Design for Controlling Rotary Drilling System. Proceedings of the 2005 IEEE Conference on Control Applications Toronto, Canada, August, 2005: 120-124.
- [10] A. F. A. Serrarens. H ∞ control as applied to torsional drillstring dynamics. Msc. Thesis, Eindhoven University of Technology, 2002.
- [11] Eva M. Navarro-López and Domingo Cortés. Sliding-mode control of a multi-DOF oilwell drillstring with stick-slip oscillations. Proceedings of the 2007 American Control Conference New York City, USA, July, 2007.
- [12] F. Abdulgalil and H. Siguerdidjane. PID Based on Sliding Mode Control for Rotary Drilling System. Serbia & Montenegro, Belgrade, November, 2005.
- [13] Eva Maria Navarro-López and Rodolfo Suárez, "Practical Approach to Modelling and Controlling Stick-slip oscillations in oilwell drillstrings", Proceedings of the 2004 IEEE International Conference on Control Applications Taipei. Taiwan, September 2-4, 2004, pp.1454-1460.
- [14] A.S.Yigit and A.P.Christoforou, "Coupled Torsional and Bending Vibrations of Actively Controlled Drillstring

Journal of Sound and Vibration, vol. 234, no.1, 2000, pp. 67-83.

- [15] N.Mihajlovic, Torsional and Lateral, "Vibrations in Flexible Rotor Systems with Friction", Technische Universiteit Eindhoven, 2005.
- [16] N.Mihajlovic, N.van de Wouw, R.C.J.N.Rosille and H.Nijmeijer, "Interaction between torsional and lateral vibrations in flexible rotor systems with discontinuous friction", Nonlinear Dynamics, vol. 50, no. 3, November 2007, pp 679-699.
- [17] Guan Cheng. Sliding Mode Adaptive Control of Nonlinear System and Application to Electro-Hydraulic Control System[D]. Zhejiang University Doctoral Dissertation, 2005.
- [18] Hu Qinglei, Ma Guangfu, Jiang Ye, Liu Yaqu. Variable structure control with time-varying sliding mode and vibration control for flexible satellite[J]. Control Theory & Application, 2009, 26(2): 122-126.
- [19] Guan Cheng, Zhu Shan-an. Derivative and Integral Sliding Mode Adaptive Control for A Class of Nonlinear System and Its Application to An Electro-Hydraulic Servo System[J]. Proceedings of the CSEE, 2005, 25(4): 103-108.
- [20] F. Abdulgalil, H. Siguerdidjane. Nonlinear control design for suppressing stick slip oscillations in oil well drillstrings, 5th ASCC, Melbourne, July 2004.
- [21] Xu Wenlin, Wu Ronghui. Lyapunov's Indirect Method for Stability Analysis of Fuzzy Control System[J]. Journal of Hunan University, 2004, 31(3): 86-89.
- [22] ZHANG Qi-zhi, HE Yu-yao, LI Lin. Sliding Mode Control of Rotary Drilling System With Stick Slip Oscillation. The 2nd International Workshop on Intelligent Systems and Applications (ISA2010), Wuhan, China, May, 2010: 30-33.

Drilling Rig Controlling Technique, Xi'an Shiyou University. Her main interests at the moment are the automatic control of electronic drilling rig.



Nurzat.Rasol was born in 1984, and received her B.S. degree in control theory and engineering from Xi'an Shiyou University in 2002, now a M.S. candidate at the Key Laboratory of Drilling Rigs Controlling Technique. Her research interests are learning real-time drilling monitoring and control system.



Lin Li was born in 1963, and received his M.S degree in 1991 with auto-measurement technique from Xi'an Jiaotong University.

Since 1993 he has been a professor at the Electrical Engineering Department and the Chief of Science and Technology Division in the Xi'an Shiyou University, published *Automatic Technology for Long Distance Pipeline*, Petroleum Industry Press, 2005, Beijing; *Automatic Technology for The Electronic Drilling Rig*, Petroleum Industry Press, 2009, Beijing. His main interests at moment are the automatic control of electronic drilling rig.

Mr .Li is a membership of China Petroleum Institute and Deputy Chairman of Shaanxi High-Tech Association, has won second place in Science and Technology Prize of Shaanxi Province and first prize in Science and Technology Prize of Shaanxi Advanced School.



Qizhi Zhang was born in 1965, and received the B.S. degrees in electronic control technical in 1987 from Beijing University of Aeronautics & Astronautics and M.S. degrees in control theory and engineering in 1992 from college of automatic control, Northwestern Polytechnical University. She is currently a professor of control science and engineering in the Key Laboratory of